

South Australia

Electricity (Principles of Vegetation Clearance) Regulations 2021

under the *Electricity Act 1996*

Contents

- 1 Short title
- 2 Commencement
- 3 Interpretation
- 4 Duty of electricity entity or council
- 5 Duty of occupier
- 6 Planting and nurturing vegetation near powerlines
- 7 Technical Regulator may grant exemption from principles of vegetation clearance
- 8 Vegetation clearance scheme outside prescribed areas agreed between council and electricity entity
- 9 Agreement between occupier and electricity entity
- 10 Objections relating to vegetation clearance
- 11 Notification of clearance by electricity entity to council
- 12 Electricity entity vegetation clearance power—prescribed qualification

Schedule 1—Clearance and buffer zones around overhead powerlines

- 1 Legend for diagrams
- 2 Clearance zone around overhead powerlines on public land in a non-bushfire risk area
- 3 Clearance and buffer zones around overhead powerlines on private land in a non-bushfire risk area
- 4 Clearance and buffer zones around overhead powerlines in the bushfire risk area
- 5 Tables for determination of value of V, H, B, S and P
- 6 Technical Regulator may determine values for clearance zone around particular powerline in certain circumstances

Schedule 2—Planting or nurturing vegetation near public powerlines

- 1 Interpretation
- 2 General rules
- 3 Exemption
- 4 Table

Schedule 3—Revocation of *Electricity (Principles of Vegetation Clearance) Regulations 2010*

Legislative history

1—Short title

These regulations may be cited as the *Electricity (Principles of Vegetation Clearance) Regulations 2021*.

2—Commencement

These regulations come into operation on 1 September 2021.

3—Interpretation

- (1) In these regulations, unless the contrary intention appears—

Act means the *Electricity Act 1996*;

buffer zone, in relation to an overhead powerline in the bushfire risk area or on private land in a non-bushfire risk area, means the space around the powerline that adjoins the clearance zone around that powerline, as shown in the diagrams in Schedule 1;

bushfire risk area means the part of the State shown in the maps published on a website determined by the Technical Regulator and identified as the bushfire risk area (and excluding the areas shown in those maps as non-bushfire risk areas);

centreline, in relation to a powerline, means—

- (a) in the case of an underground powerline—
 - (i) that consists of a single conductor—an imaginary line on the ground directly above that conductor; or
 - (ii) that consists of more than 1 conductor—an imaginary line on the ground above the powerline that is equidistant from the outer conductors; or
- (b) in the case of an overhead powerline—
 - (i) that consists of a single conductor—an imaginary line on the ground directly beneath the position maintained by that conductor in still air; or
 - (ii) that consists of more than 1 conductor—an imaginary line on the ground below the powerline that is equidistant from the positions maintained by the outer conductors in still air;

clearance zone means the space around an overhead powerline as shown in the diagrams in Schedule 1 (the values of V, H, B, S and P referred to in those diagrams being determined by reference to the tables in Schedule 1 clause 5 or, if a determination of the Technical Regulator under Schedule 1 clause 6 is in force in relation to a particular powerline, that determination);

low risk powerline means an overhead powerline or portion of an overhead powerline—

- (a) that is in a prescribed area; and
- (b) each span of which does not exceed 50 m and has low voltage conductors;

low voltage conductor means a conductor constructed to operate at a voltage not exceeding 480V;

non-bushfire risk area means a part of the State not within the bushfire risk area;

prescribed area—see subregulation (3);

private powerline—see subregulation (2);

public land means land other than private land;

span, in relation to an overhead powerline, means the part of the powerline that lies between 2 poles or other supports for that line.

- (2) For the purposes of the definition of *private powerline* in section 4(1) of the Act, the prescribed voltage is 19kV.
- (3) For the purposes of Part 5 of the Act and these regulations, each non-bushfire risk area (or portion of a non-bushfire risk area) that is shown in a map published on a website determined by the Technical Regulator is a *prescribed area* except where such an area (or portion of such an area) is indicated to be a *non-bushfire risk area (not prescribed)*.

4—Duty of electricity entity or council

- (1) The principles of vegetation clearance set out in this regulation are prescribed for the purposes of Part 5 of the Act and govern the duty of an electricity entity or a council to take reasonable steps to keep vegetation clear of powerlines.
- (2) At intervals of no longer than 3 years, overhead powerlines must be inspected and vegetation cleared as follows:
 - (a) in the case of powerlines other than low risk powerlines—vegetation must be cleared so that—
 - (i) no vegetation remains in the clearance zone surrounding the powerline in still air at the time of the clearance; and
 - (ii) no growth or regrowth is likely to intrude into the clearance zone within 3 years (or, if an inspection and clearance is scheduled to take place in less than 3 years, within that lesser period), taking into account the reasonably ascertainable characteristics of the powerline and vegetation; and
 - (iii) no part of the vegetation or growth or regrowth is likely to bend in the wind into the clearance zone at the time of clearance or within 3 years (or, if an inspection and clearance is scheduled to take place in less than 3 years, within that lesser period), taking into account the reasonably ascertainable characteristics of the powerline and vegetation and winds that might reasonably be expected in the area;
 - (b) in the case of low risk powerlines—vegetation must be cleared—
 - (i) in accordance with the principles set out in paragraph (a); or
 - (ii) so that no part of the vegetation or growth or regrowth is likely to come into contact with the powerline (including by bending in the wind) so as to—
 - (A) form a leakage current to ground through the vegetation resulting in a risk of fire or electric shock; or
 - (B) form an electrical path for tracking voltage exceeding 480V into low voltage conductors; or
 - (C) bridge 2 or more low voltage conductors resulting in a phase to phase or phase to neutral breach; or
 - (D) cause damage to the powerline resulting in a risk of fire, electric shock or loss of electricity supply,

at the time of the clearance or within 3 years (or, if an inspection and clearance is scheduled to take place in less than 3 years, within that lesser period), taking into account the reasonably ascertainable characteristics of the powerline and the vegetation and winds that might reasonably be expected in the area.

- (3) If the supporting structure of a low risk powerline also supports conductors that are not low voltage conductors, then—
 - (a) the principles set out in subregulation (2)(a) apply in relation to the conductors that are not low voltage conductors; and
 - (b) the principles set out in subregulation (2)(b) apply in relation to the low voltage conductors.
- (4) The principles set out in subregulation (2)(b)(ii) only apply if the Technical Regulator has given approval to the electricity entity or council to keep vegetation clear of the powerlines in accordance with those principles.
- (5) If an electricity entity has the duty to keep vegetation clear of the powerlines—
 - (a) the entity must not, in clearing vegetation in accordance with the principles set out in subregulation (2)(a), clear vegetation from around an overhead powerline—
 - (i) more than is reasonably necessary to satisfy those principles; or
 - (ii) if there is a buffer zone around the powerline, beyond the buffer zone,
except if—
 - (iii) it is reasonably necessary to do so for the purposes of—
 - (A) enhancing the stability or health of remaining vegetation; or
 - (B) enhancing the appearance of remaining vegetation (but in that case, if there is a buffer zone around the powerline, the vegetation must not be cleared beyond the buffer zone); or
 - (iv) the vegetation to be cleared consists of plants that have grown wholly in the immediately preceding 5 years and the vegetation is identified as being of a species that will grow into the clearance zone around the powerline; or
 - (v) the entity agrees, at the request of the occupier of the land on which the vegetation is situated, to undertake the clearance and the clearance would not be contrary to the provisions of any other law if carried out by the occupier; and
 - (b) the entity must not, in clearing vegetation in accordance with the principles set out in subregulation (2)(b)(ii), clear more vegetation than it could by clearing in accordance with the principles set out in subregulation (2)(a).
 - (6) The Technical Regulator may require an electricity entity to prepare guidelines in respect of the clearance of vegetation in accordance with subregulation (5)(a)(iv).

- (7) If a council has the duty to keep vegetation clear of the powerlines, the council need not, in clearing vegetation in accordance with the principles set out in subregulation (2)(b)(ii), clear more vegetation than would be reasonably necessary to satisfy the principles set out in subregulation (2)(a).

5—Duty of occupier

- (1) The principles of vegetation clearance set out in this regulation are prescribed for the purposes of Part 5 of the Act and govern the duty of an occupier of private land to take reasonable steps to keep vegetation clear of private powerlines on the land.
- (2) An occupier of private land must keep vegetation (other than naturally occurring vegetation) clear of any private overhead powerline on that land so that—
- (a) no part of the vegetation at any time intrudes into the clearance zone around that powerline in still air; and
 - (b) no part of the vegetation is at any time likely to bend into that zone in winds that might reasonably be expected in the area.
- (3) An occupier of private land is not required to clear vegetation beyond the buffer zone around any powerline.
- (4) An occupier of private land must not clear vegetation which the occupier may not lawfully clear apart from this regulation—
- (a) more than is reasonably necessary to satisfy the requirements of subregulation (2) and for the purposes of enhancing the appearance, stability or health of any remaining vegetation; or
 - (b) if there is a buffer zone around the powerline, beyond the buffer zone.

6—Planting and nurturing vegetation near powerlines

For the purposes of Part 5 of the Act, Schedule 2 sets out requirements for planting or nurturing vegetation near powerlines.

7—Technical Regulator may grant exemption from principles of vegetation clearance

- (1) The Technical Regulator may, on application—
- (a) exempt an occupier of land on which vegetation is planted or nurtured for commercial purposes (not including the production of timber) from compliance with regulation 5; or
 - (b) exempt a person from compliance with a provision of Schedule 2 in relation to specified vegetation.
- (2) An application under this regulation must—
- (a) be made in a form approved by the Technical Regulator; and
 - (b) contain the information specified in the form; and
 - (c) be accompanied by an application fee fixed by the Minister.
- (3) Before determining an application under this regulation, the Technical Regulator must give the electricity entity or council with the duty to keep the vegetation clear of powerlines a reasonable opportunity to make submissions and be heard on the matter.

- (4) An exemption under this regulation—
- (a) must be in writing; and
 - (b) may be subject to conditions, including a condition that the applicant is to pay any costs that the electricity entity or council incur in keeping the vegetation clear of powerlines in accordance with these regulations.
- (5) A person who contravenes, or fails to comply with, a condition of an exemption under this regulation is guilty of an offence.
- Maximum penalty: \$5 000.
- Expiation fee: \$315.

8—Vegetation clearance scheme outside prescribed areas agreed between council and electricity entity

- (1) This regulation applies to public land in a non-bushfire risk area but not within a prescribed area.
- (2) An electricity entity may agree a vegetation clearance scheme with a council governing the way in which the entity will carry out its duty to clear vegetation in the area of the council or part of that area.
- (3) The factors that should be taken into consideration in formulating a scheme include the following:
- (a) the nature of the vegetation, including its expected rate of growth;
 - (b) the impact that the clearance work would be likely to have on the amenity of the area;
 - (c) the historical or biological significance (if any) of the vegetation;
 - (d) the long term effect that the clearance work would be likely to have on the health and appearance of the vegetation;
 - (e) the controls on the planting and nurturing of vegetation applicable in the area;
 - (f) the need to prevent damage to the powerlines and interruption to the supply of electricity and to safeguard the public against electric shock and damage to property;
 - (g) the extent and frequency of past vegetation clearance in the area;
 - (h) whether requirements with respect to vegetation clearance and the planting and nurturing of vegetation have been complied with in the area and, if not, the reasons for the non-compliance;
 - (i) the existence and terms of other vegetation clearance schemes;
 - (j) any proposal to alter, remove or underground powerlines in the area;
 - (k) the costs of the proposals (including insurance premiums) to the council and to the electricity entity and the financial resources of the council and entity;
 - (l) the limits on the financial and other resources of the electricity entity that may be devoted to the scheme and the schemes for the areas of other councils;
 - (m) any arrangement between the electricity entity and the council conferring on the council a specified role in relation to vegetation clearance.

- (4) A scheme cannot derogate from the principles set out in regulation 4.
- (5) A scheme—
 - (a) must be in writing and executed by the council and the electricity entity (however, separate execution is not required if the scheme is combined with an arrangement under Part 5 of the Act conferring on the council a specified role in relation to vegetation clearance); and
 - (b) may be varied or revoked by written agreement between the parties.
- (6) A vegetation clearance scheme as agreed has effect, and may be enforced, as a contract between the electricity entity and the council concerned.

9—Agreement between occupier and electricity entity

- (1) An electricity entity may enter into an agreement with an occupier of private land under which—
 - (a) vegetation around powerlines in a specified area of the land is to be inspected and cleared more frequently than required under regulation 4; or
 - (b) the occupier undertakes to carry out the required inspection and clearance of vegetation on that land on behalf of the entity.
- (2) The agreement—
 - (a) must be in writing and executed by the occupier and the electricity entity; and
 - (b) must specify—
 - (i) the area concerned; and
 - (ii) the intervals at which inspection and clearance must be carried out; and
 - (iii) unless the occupier undertakes to carry out the inspections and clearance on behalf of the electricity entity—the payments agreed between the parties in respect of the costs of the additional work required under the agreement; and
 - (c) may be varied or revoked by further written agreement between the parties; and
 - (d) has effect, and may be enforced, as a contract between the electricity entity and the occupier.

10—Objections relating to vegetation clearance

- (1) An occupier or owner of private land may lodge an objection with the Technical Regulator concerning a matter set out in a notice of intention to enter land to carry out work received from an electricity entity or council under Part 5 of the Act.
- (2) An objection under this regulation must—
 - (a) be made to the Technical Regulator in writing; and
 - (b) be lodged with the Technical Regulator within 21 days after receipt of the notice to which the objection relates or such further time as the Technical Regulator allows.

- (3) The Technical Regulator must, on receipt of an objection, notify the electricity entity or council, as the case may require, of the objection.
- (4) On receiving notification of the objection, the electricity entity or council is prohibited from carrying out the clearance of vegetation to which the objection relates until the objection has been determined by the Technical Regulator.
- (5) The Technical Regulator may—
 - (a) dismiss the objection; or
 - (b) direct the electricity entity or council to take or to refrain from taking any specified action in relation to the matter; or
 - (c) if the objector and the electricity entity or council have reached an agreement as to how the objection might be resolved, and the agreement does not involve a breach of these regulations—determine the objection so as to reflect the agreement.
- (6) The Technical Regulator may dismiss the objection—
 - (a) on the ground that—
 - (i) the subject matter of the objection is substantially the same as the subject matter of an objection previously considered; or
 - (ii) the objection is frivolous or vexatious or without reasonable basis; or
 - (iii) the objector has not made a reasonable attempt to resolve the matter by agreement with the electricity entity or council; or
 - (b) if satisfied that the objector and the electricity entity or council have entered into an agreement under regulation 9 that relates to the subject matter of the objection; or
 - (c) if satisfied for any other reason that the objection should not be allowed.
- (7) The Technical Regulator must, as soon as practicable, notify the objector and the electricity entity or council, as the case may require, of the Technical Regulator's determination of the objection.
- (8) An electricity entity or council must, when giving notice of an intention to enter private land to carry out work under Part 5 of the Act, include in or with the notice a statement of the rights of the owner or occupier to lodge an objection under this regulation.

11—Notification of clearance by electricity entity to council

- (1) An electricity entity must give a council not less than 30 days written notice before commencing a program of vegetation clearance in the area of the council, including details of when and where clearance is to take place under the program.
- (2) Subregulation (1) does not apply if the clearance work to be carried out is subject to a vegetation clearance scheme.

12—Electricity entity vegetation clearance power—prescribed qualification

For the purposes of section 55AA(2) of the Act, the prescribed qualification is a diploma in arboriculture obtained from a training organisation registered under the *South Australian Skills Act 2008* or a law of the Commonwealth, or another State or Territory, relating to training and skills development.

Schedule 1—Clearance and buffer zones around overhead powerlines

1—Legend for diagrams

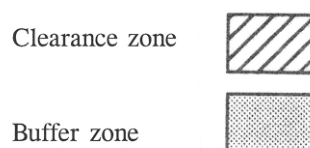

2—Clearance zone around overhead powerlines on public land in a non-bushfire risk area

(1) **Diagram A—public land in non-bushfire risk area—fully insulated or low voltage**

This diagram applies to a powerline that has conductors which are fully insulated (for example, aerial bundled cables) or low voltage conductors.

The clearance zone as shown extends along the length of each span of the powerline.

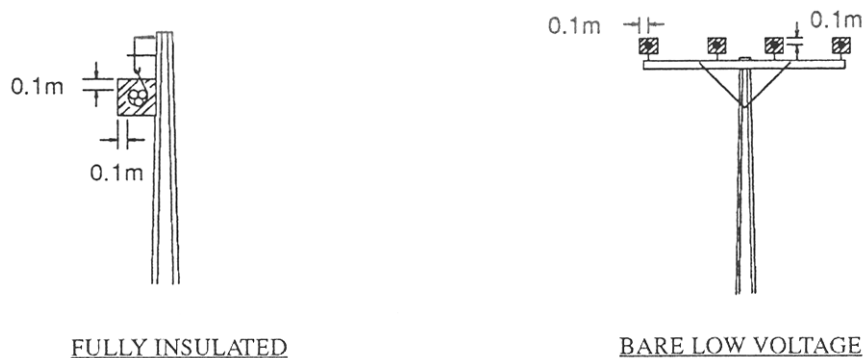

0.1m dimension is from conductor positions in still air.

(2) **Diagram B—public land in non-bushfire risk area—insulated unscreened**

This diagram applies to a powerline the conductors of which are Insulated Unscreened Conductor ("IUC" or "CCT").

The clearance zone as shown extends along the length of each span of the powerline.

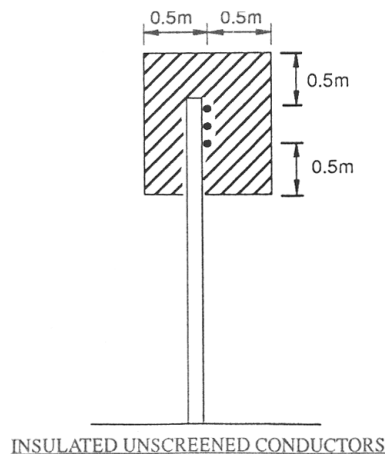

0.5m dimension is from conductor positions in still air.

(3) **Diagram C—public land in non-bushfire risk area—not insulated more than 480V but less than 33kV**

These diagrams apply to a powerline, the conductors of which are not insulated, constructed to operate at a voltage of more than 480V but less than 33kV.

Diagram C.1 shows the clearance zone at the pole or other support at the end of each span of the powerline.

Diagram C.2 shows the clearance zone at mid span (as shown in diagrams C.3 and C.4) for each span of the powerline.

Diagrams C.3 and C.4 show the manner in which the clearance zone extends along the length of each span of the powerline.

The values of V, H and P are set out in Tables 1 and 2 in clause 5.

C.1—public land in non-bushfire risk area—not insulated more than 480V but less than 33kV—at each end of span

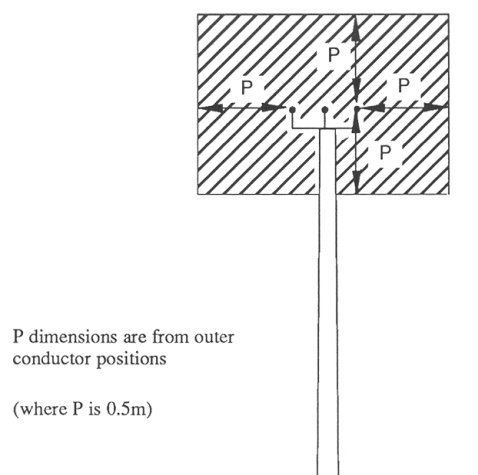

C.2—public land in non-bushfire risk area—not insulated more than 480V but less than 33kV—mid span (as shown in diagrams C.3 and C.4)

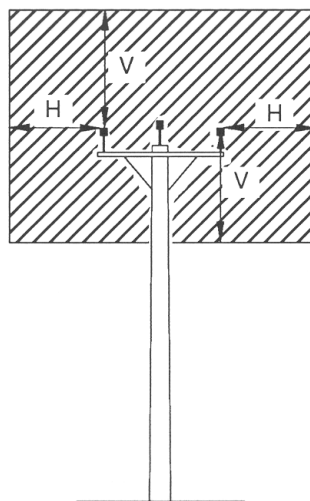

V & H dimensions are from outer conductor positions in still air.

C.3—public land in non-bushfire risk area—not insulated more than 480V but less than 33kV—view of clearance zone from above

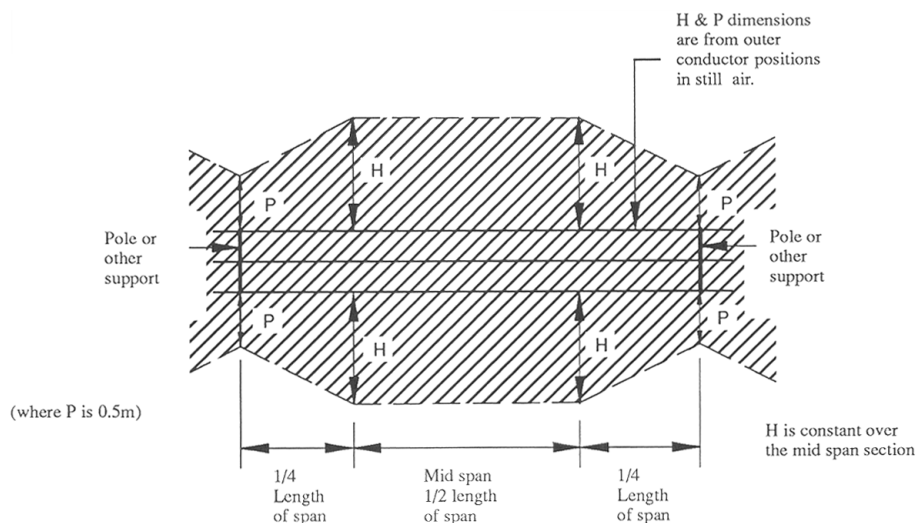

C.4—public land in non-bushfire risk area—not insulated more than 480V but less than 33kV—view of clearance zone from side

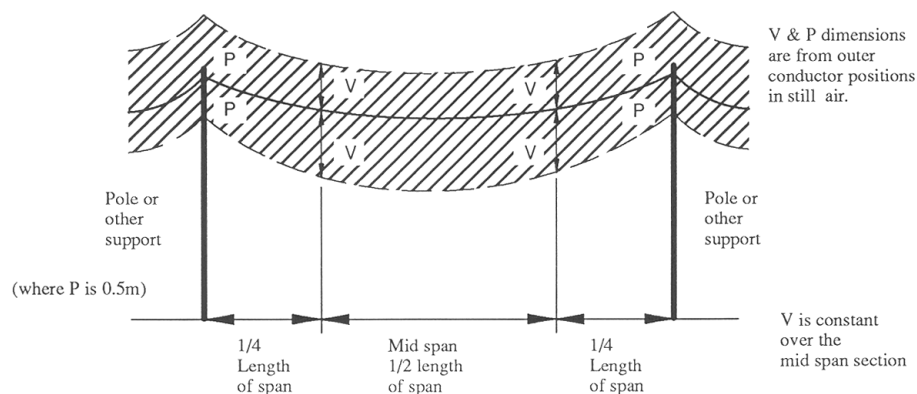

(4) **Diagram D—public land in non-bushfire risk area—not insulated 33kV to 66kV**

These diagrams apply to a powerline, the conductors of which are not insulated, constructed to operate at a voltage from 33kV to 66kV inclusive.

Diagram D.1 shows the clearance zone at the pole or other support at the end of each span of the powerline.

Diagram D.2 shows the clearance zone at mid span (as shown in diagrams D.3 and D.4) for each span of the powerline.

Diagrams D.3 and D.4 show the manner in which the clearance zone extends along the length of each span of the powerline.

The values of V, H and P are set out in Table 3 in clause 5.

D.1—public land in non-bushfire risk area—not insulated 33kV to 66kV—at each end of a span

No ceiling on Clearance Zone

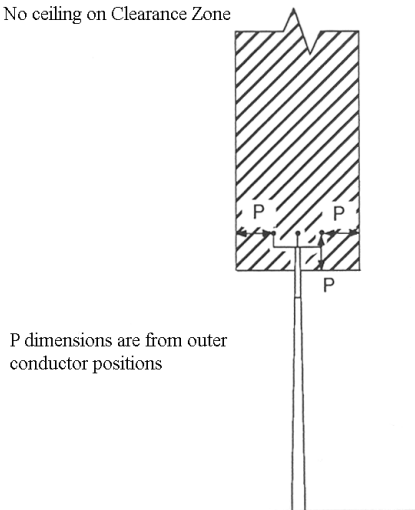

D.2—public land in non-bushfire risk area—not insulated 33kV to 66kV—mid span (as shown in diagrams D.3 and D.4)

No ceiling on Clearance Zone

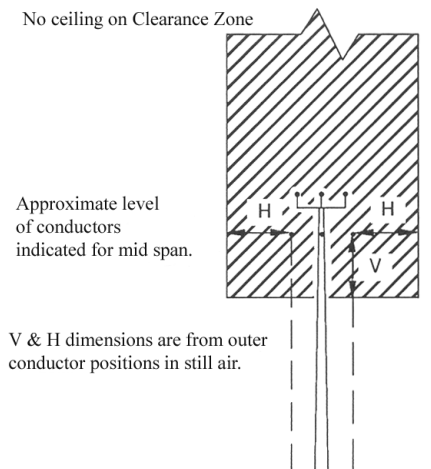

D.3—public land in non-bushfire risk area—not insulated 33kV to 66kV—view of clearance zone from above

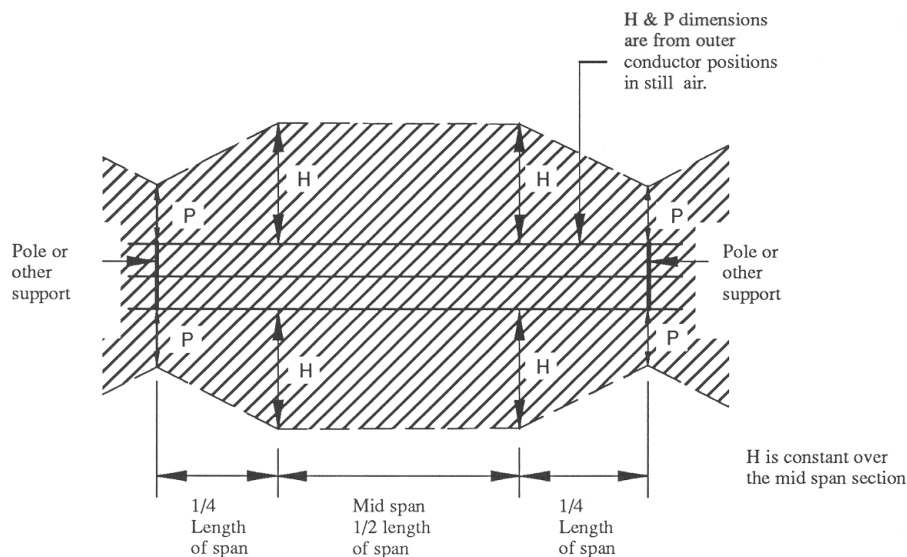

D.4—public land in non-bushfire risk area—not insulated 33kV to 66kV—view of clearance zone from side

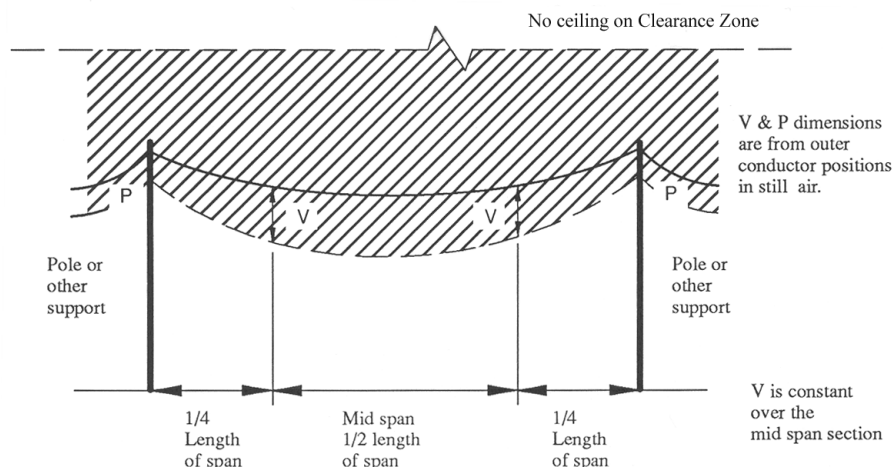

(5) **Diagram E—public land in non-bushfire risk area—not insulated 132kV to 275kV**

These diagrams apply to a powerline, the conductors of which are not insulated, constructed to operate at a voltage from 132kV to 275kV inclusive.

Diagram E.1 shows the clearance zone at the pole or other support at the end of each span of the powerline.

Diagram E.2 shows the clearance zone at mid span (as shown in diagrams E.3 and E.4) for each span of the powerline.

Diagrams E.3 and E.4 show the manner in which the clearance zone extends along the length of each span of the powerline.

The values of V, H, S and P are set out in Table 4 in clause 5.

The 45° component of the clearance zone is determined as being 3 m from the 45° cutoff line.

E.1—public land in non-bushfire risk area—not insulated 132kV to 275kV—at each end of a span

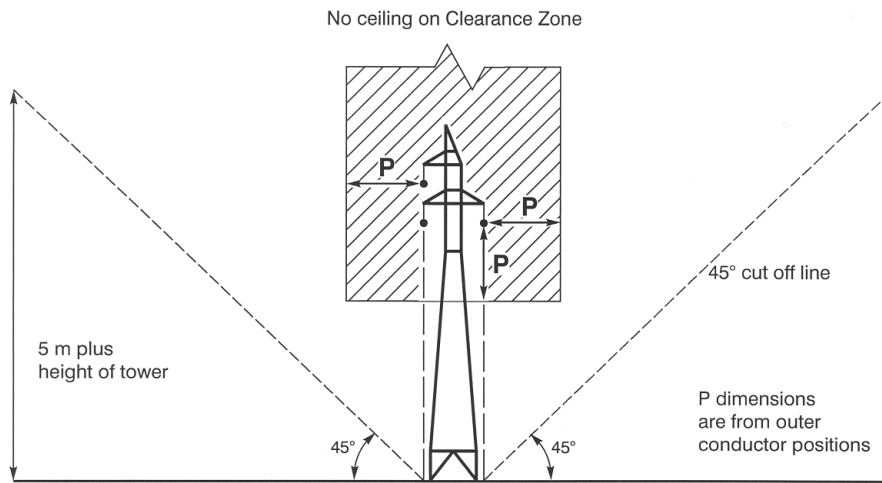

E.2—public land in non-bushfire risk area—not insulated 132kV to 275kV—mid span (as shown in diagrams E.3 and E.4)

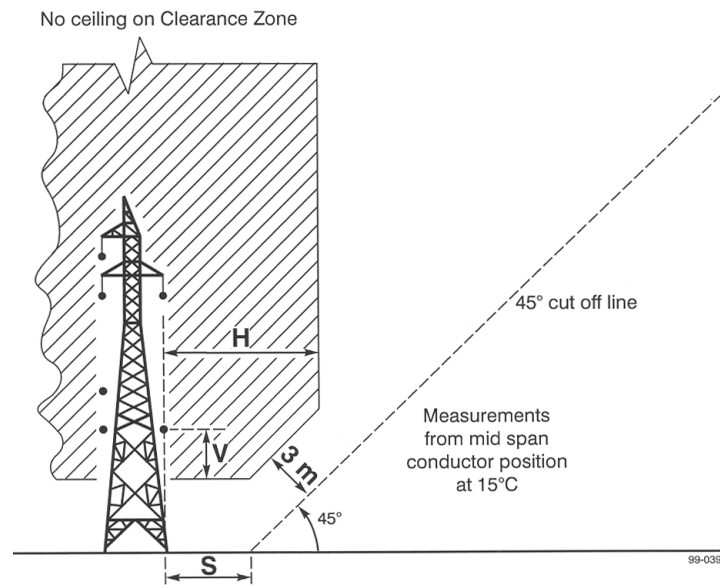

E.3—public land in non-bushfire risk area—not insulated 132kV to 275kV—view of clearance zone from above

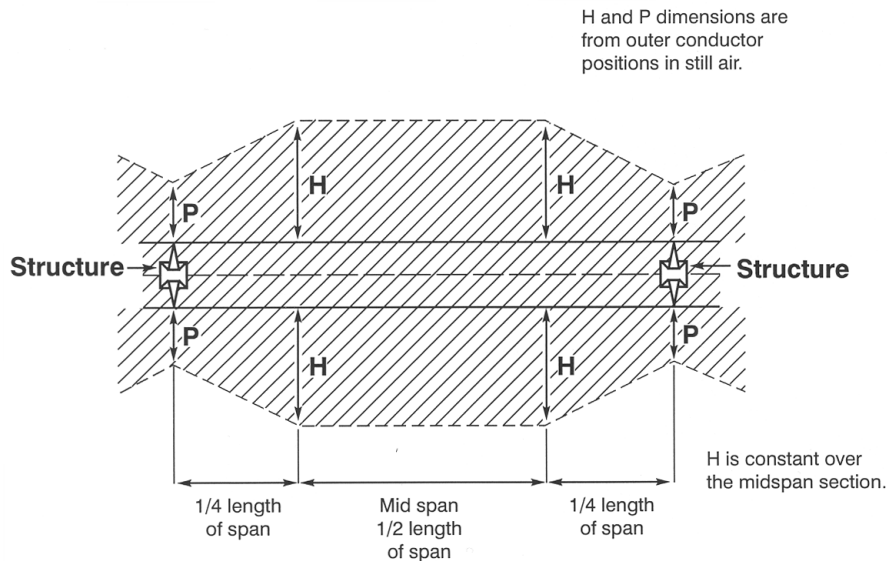

E.4—public land in non-bushfire risk area—not insulated 132kV to 275kV—view of clearance zone from side

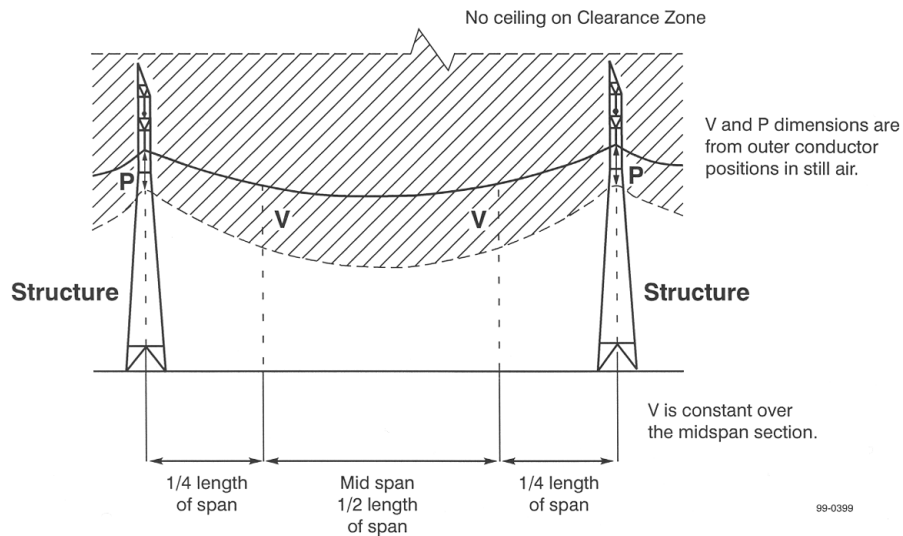

3—Clearance and buffer zones around overhead powerlines on private land in a non-bushfire risk area

(1) **Diagram A—private land in non-bushfire risk area—fully insulated or low voltage**

This diagram applies to a powerline that has conductors which are fully insulated (for example, aerial bundled cables) or low voltage conductors.

The zones as shown extend along the length of each span of the powerline.

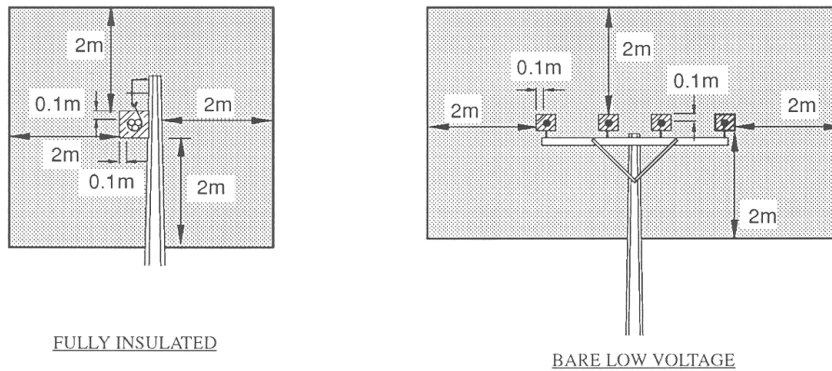

0.1 m dimension is from conductor positions in still air.

(2) Diagram B—private land in non-bushfire risk area—insulated unshielded

This diagram applies to a powerline the conductors of which are Insulated Unshielded Conductor ("IUC" or "CCT").

The zones as shown extend along the length of each span of the powerline.

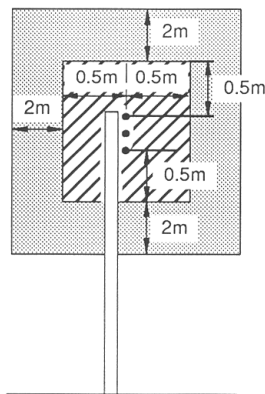

INSULATED UNSCREENED CONDUCTORS

0.5 m dimension is from conductor positions in still air.

(3) Diagram C—private land in non-bushfire risk area—not insulated more than 480V but less than 33kV

These diagrams apply to a powerline the conductors of which are not insulated, constructed to operate at a voltage of more than 480V but less than 33kV.

Diagram C.1 shows the zones at the pole or other support at the end of each span of the powerline.

Diagram C.2 shows the clearance zone at mid span (as shown in diagrams C.3 and C.4) for each span of the powerline.

Diagrams C.3 and C.4 show the manner in which the clearance zone extends along the length of each span of the powerline.

Although not shown in diagrams C.3 and C.4, the buffer zone as shown in diagrams C.1 and C.2 extends along the length of each span of the powerline.

The values of V, H and P are set out in Tables 1 and 2 in clause 5.

C.1—private land in non-bushfire risk area—not insulated more than 480V but less than 33kV—at each end of a span

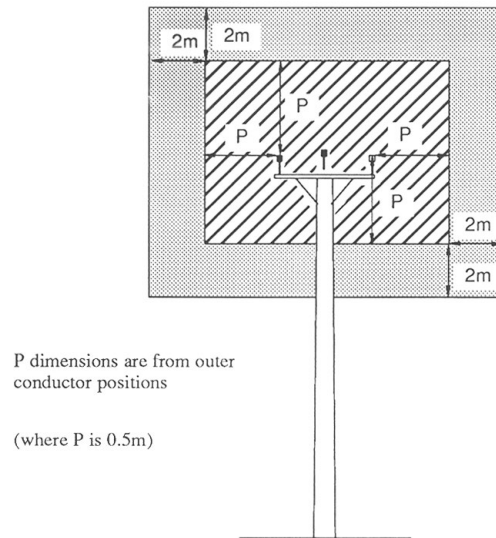

C.2—private land in non-bushfire risk area—not insulated more than 480V but less than 33kV—mid span (as shown in diagrams C.3 and C.4)

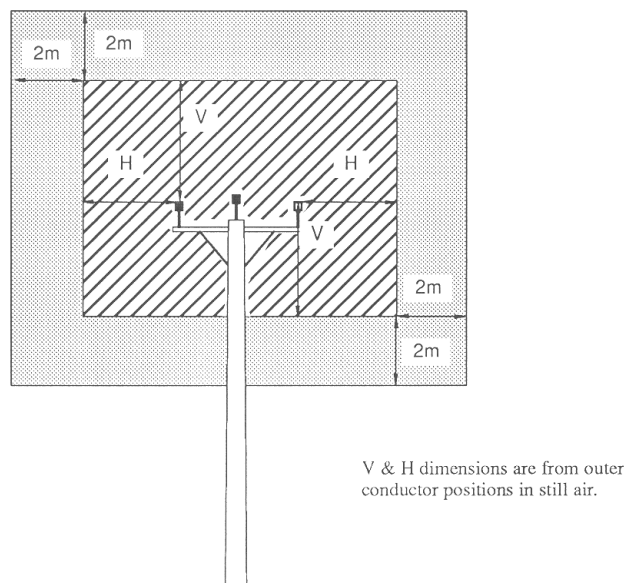

C.3—private land in non-bushfire risk area—not insulated more than 480V but less than 33kV—view of clearance zone from above

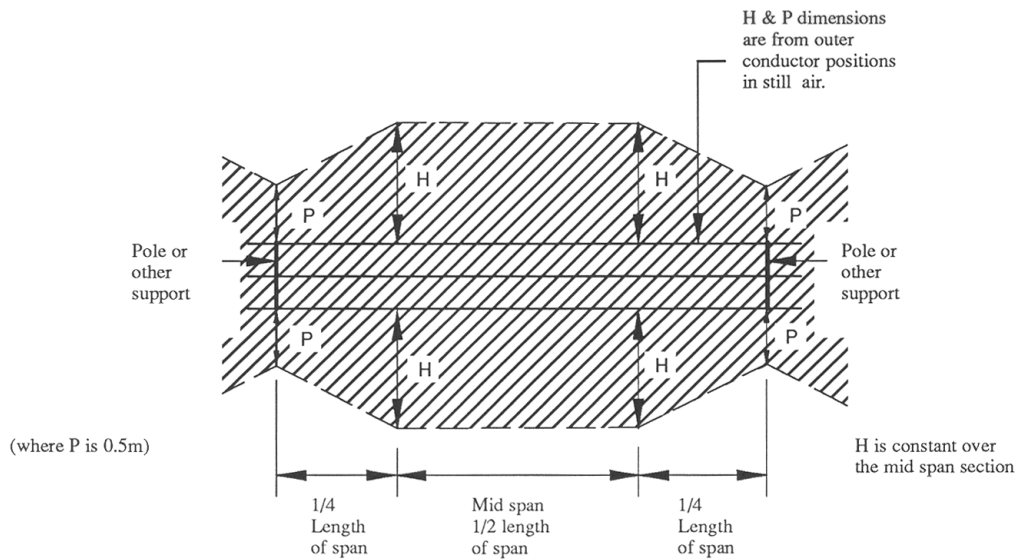

C.4—private land in non-bushfire risk area—not insulated more than 480V but less than 33kV—view of clearance zone from side

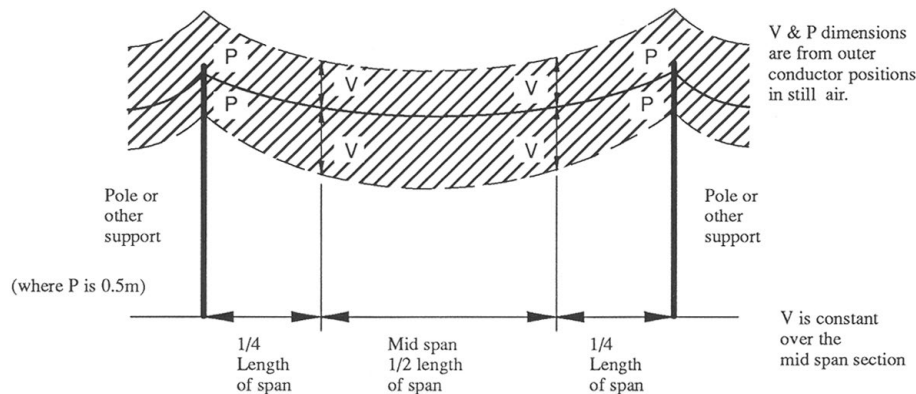

(4) Diagram D—private land in non-bushfire risk area—not insulated 33kV to 66kV

These diagrams apply to a powerline, the conductors of which are not insulated, constructed to operate at a voltage from 33kV to 66kV inclusive.

Diagram D.1 shows the zones at the pole or other support at the end of each span of the powerline.

Diagram D.2 shows the zones at mid span (as shown in diagrams D.3 and D.4) for each span of the powerline.

Diagrams D.3 and D.4 show the manner in which the clearance zone extends along the length of each span of the powerline.

Although not shown in diagrams D.3 and D.4, the buffer zone as shown in diagrams D.1 and D.2 extends along the length of each span of the powerline.

The values of V, H, B and P are set out in Table 3 in clause 5.

D.1—private land in non-bushfire risk area—not insulated 33kV to 66kV—at each end of a span

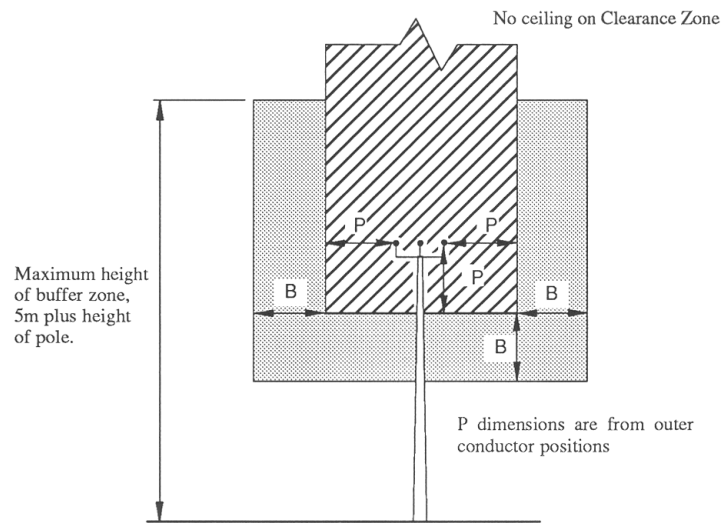

D.2—private land in non-bushfire risk area—not insulated 33kV to 66kV—mid span (as shown in diagrams D.3 and D.4)

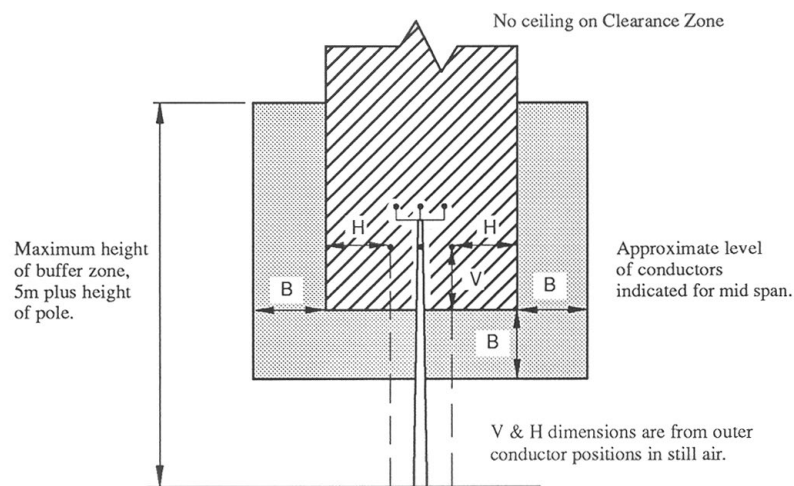

D.3—private land in non-bushfire risk area—not insulated 33kV to 66kV—view of clearance zone from above

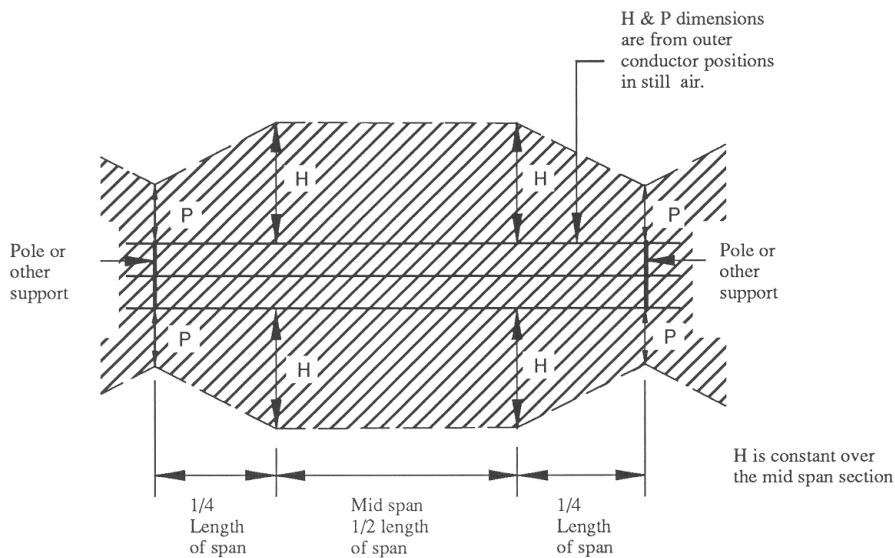

D.4—private land in non-bushfire risk area—not insulated 33kV to 66kV—view of clearance zone from side

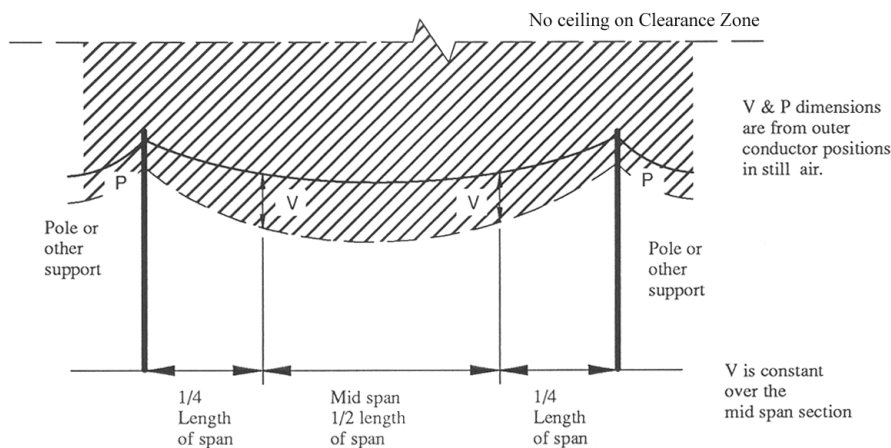

(5) **Diagram E—private land in non-bushfire risk area—not insulated 132kV to 275kV**

These diagrams apply to a powerline, the conductors of which are not insulated, constructed to operate at a voltage from 132kV to 275kV inclusive.

Diagram E.1 shows the zones at the pole or other support at the end of each span of the powerline.

Diagram E.2 shows the zones at mid span (as shown in diagrams E.3 and E.4) for each span of the powerline.

Diagrams E.3 and E.4 show the manner in which the clearance zone extends along the length of each span of the powerline.

Although not shown in diagrams E.3 and E.4, the buffer zone as shown in diagrams E.1 and E.2 extends along the length of each span of the powerline.

The values of V, H, S, B and P are set out in Table 4 in clause 5.

The 45° component of the clearance zone is determined as being 3 m inside the buffer zone.

E.1—private land in non-bushfire risk area—not insulated 132kV to 275kV—at each end of a span

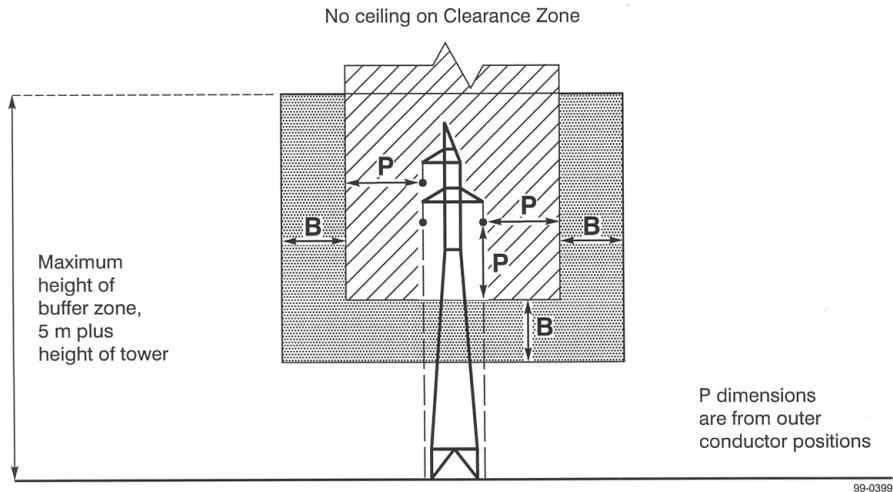

E.2—private land in non-bushfire risk area—not insulated 132kV to 275kV—mid span (as shown in diagrams E.3 and E.4)

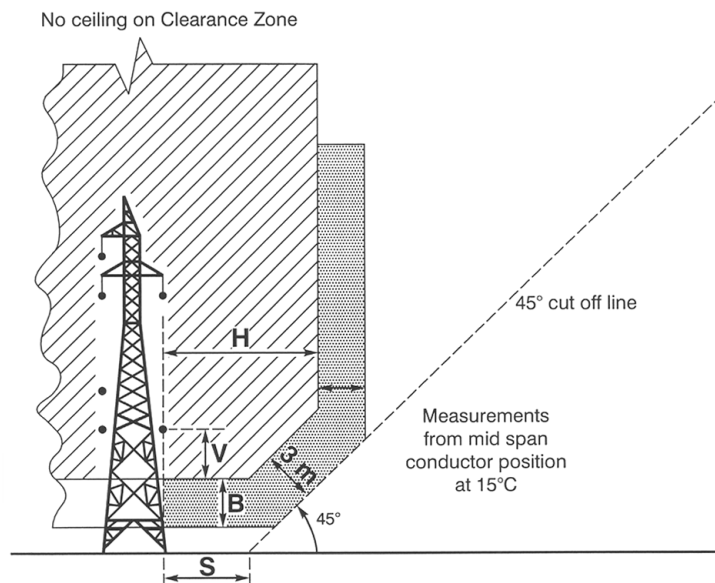

E.3—private land in non-bushfire risk area—not insulated 132kV to 275kV—view of clearance zone from above

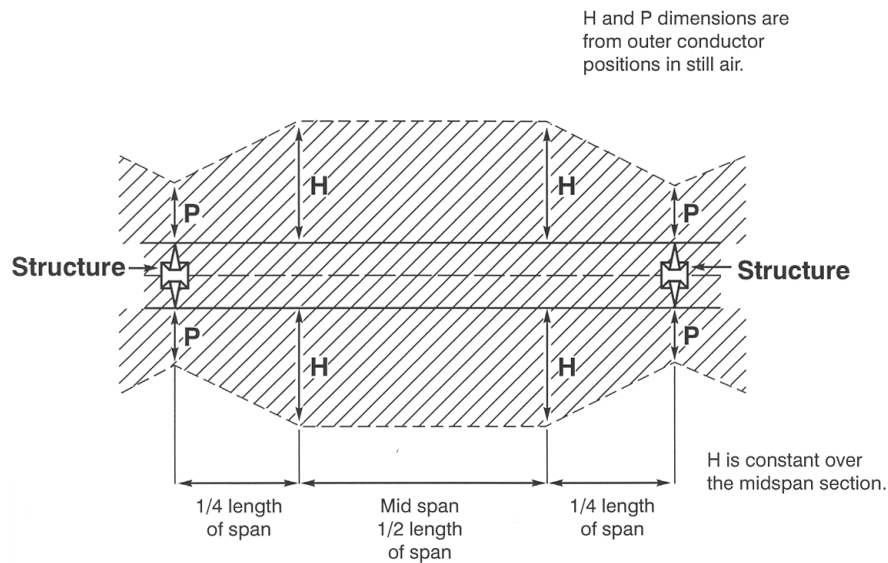

E.4—private land in non-bushfire risk area—not insulated 132kV to 275kV—view of clearance zone from side

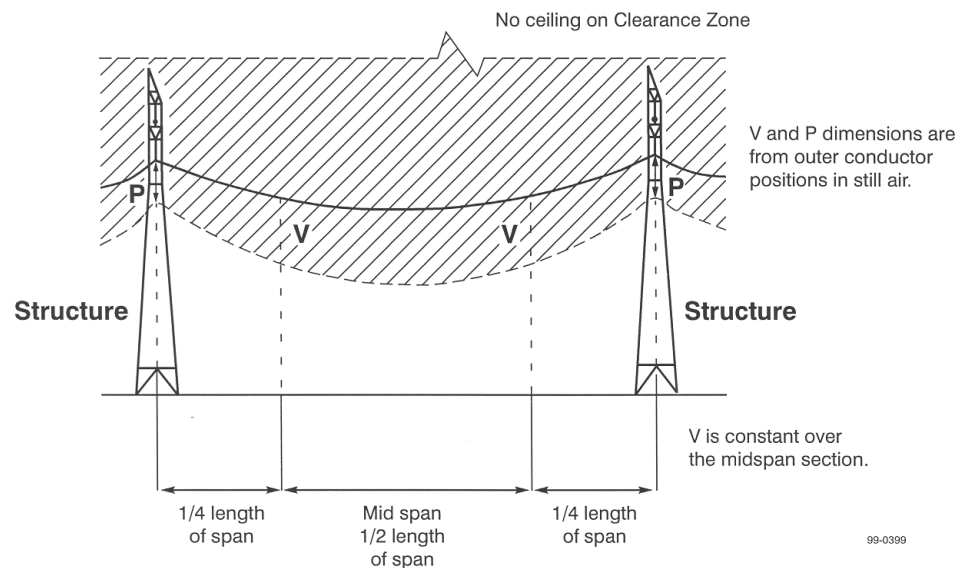

4—Clearance and buffer zones around overhead powerlines in the bushfire risk area

(1) Diagram A—bushfire risk area—fully insulated

This diagram applies to a powerline the conductors of which are fully insulated (for example, aerial bundled cables).

The zones as shown extend along the length of each span of the powerline.

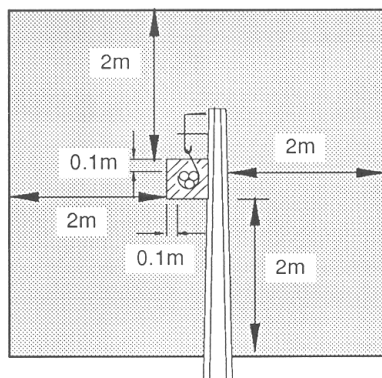

FULLY INSULATED

0.1 m dimension is from conductor position in still air.

(2) **Diagram B—bushfire risk area—insulated unscreened**

This diagram applies to a powerline the conductors of which are Insulated Unscreened Conductor ("IUC" or "CCT").

The zones as shown extend along the length of each span of the powerline.

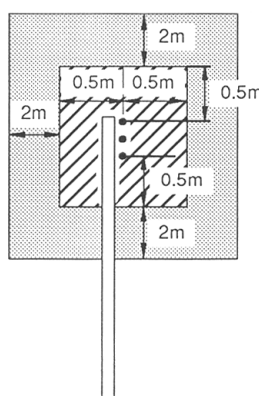

INSULATED UNSCREENED CONDUCTORS

0.5 m dimension is from conductor positions in still air.

(3) **Diagram C—bushfire risk area—not insulated less than 33kV**

These diagrams apply to a powerline, the conductors of which are not insulated, constructed to operate at a voltage of less than 33kV.

Diagram C.1 shows the zones at the pole or other support at the end of each span of the powerline.

Diagram C.2 shows the zones at mid span (as shown in diagrams C.3 and C.4) for each span of the powerline.

Diagrams C.3 and C.4 show the manner in which the clearance zone extends along the length of each span of the powerline.

Although not shown in diagrams C.3 and C.4, the buffer zone as shown in diagrams C.1 and C.2 extends along the length of each span of the powerline.

The values of V, H and P are set out in Tables 1 and 2 in clause 5.

C.1—bushfire risk area—not insulated less than 33kV—at each end of a span

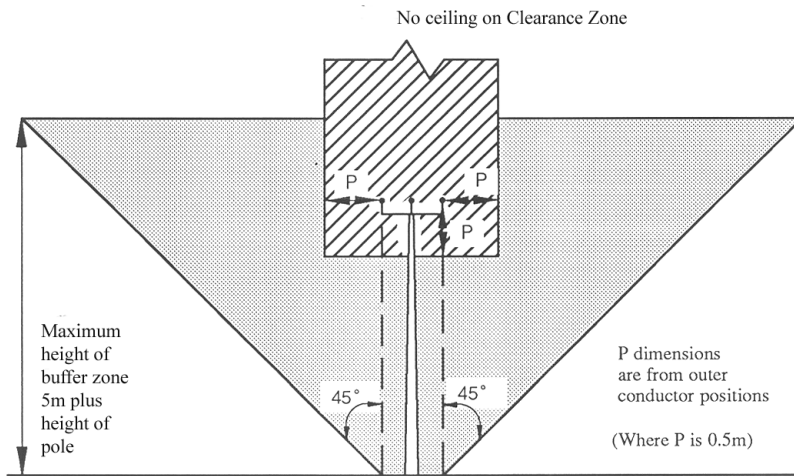

C.2—bushfire risk area—not insulated less than 33kV—mid span (as shown in diagrams C.3 and C.4)

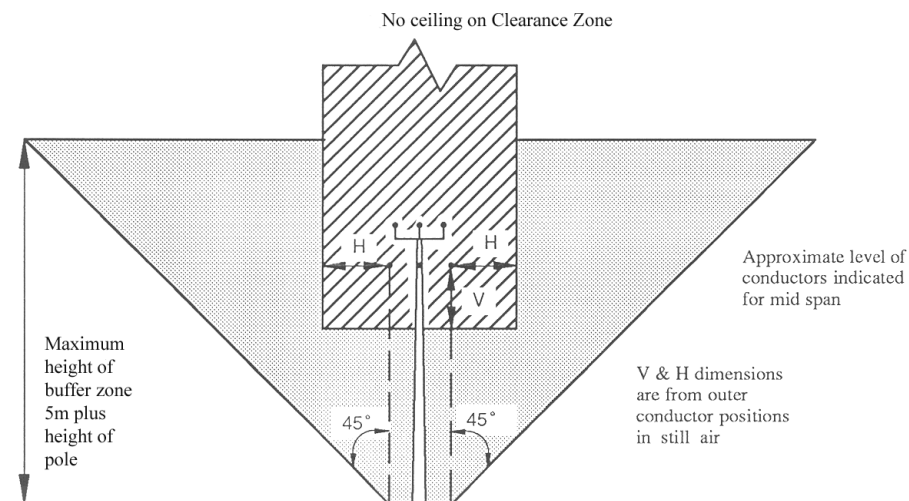

C.3—bushfire risk area—not insulated less than 33kV—view of clearance zone from above

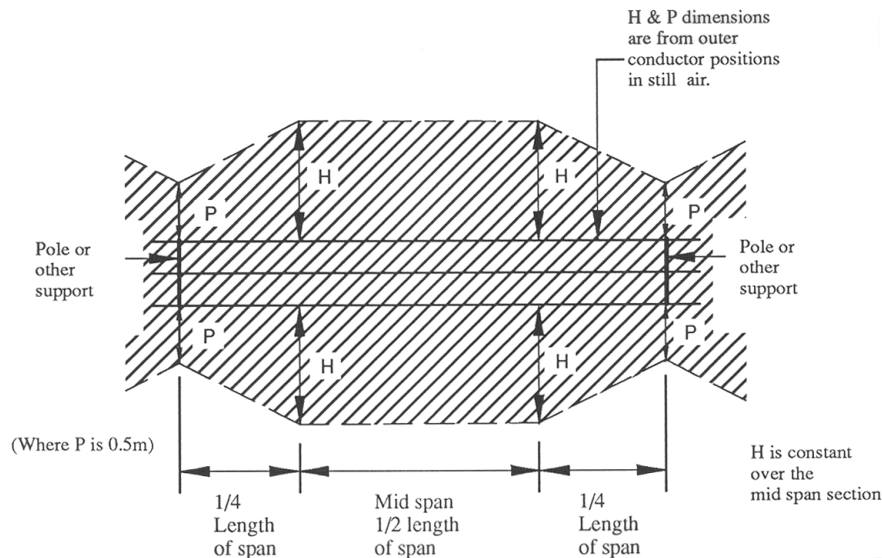

C.4—bushfire risk area—not insulated less than 33kV—view of clearance zone from side

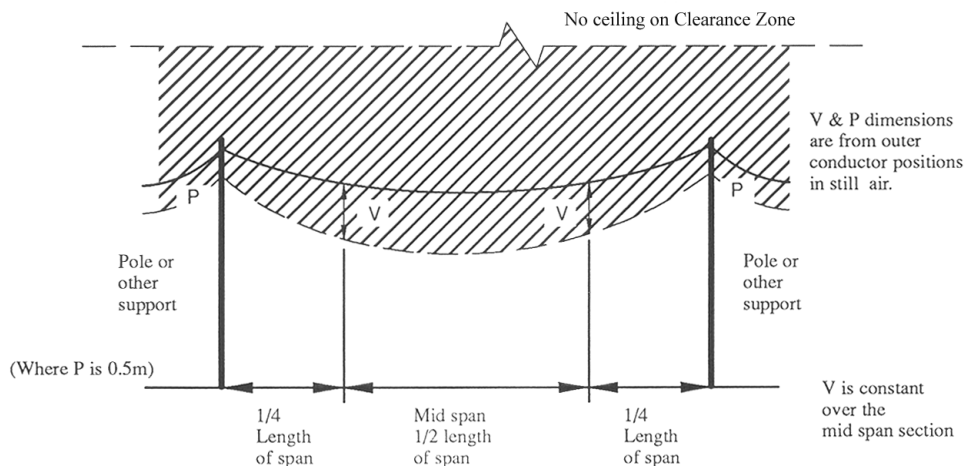

(4) Diagram D—bushfire risk area—not insulated 33kV to 66kV

These diagrams apply to a powerline, the conductors of which are not insulated, constructed to operate at a voltage from 33kV to 66kV inclusive.

Diagram D.1 shows the zones at the pole or other support at the end of each span of the powerline.

Diagram D.2 shows the zones at mid span (as shown in diagrams D.3 and D.4) for each span of the powerline.

Diagrams D.3 and D.4 show the manner in which the clearance zone extends along the length of each span of the powerline.

Although not shown in diagrams D.3 and D.4, the buffer zone as shown in diagrams D.1 and D.2 extends along the length of each span of the powerline.

The values of V, H and P are set out in Table 3 in clause 5.

D.1—bushfire risk area—not insulated 33kV to 66kV—at each end of a span

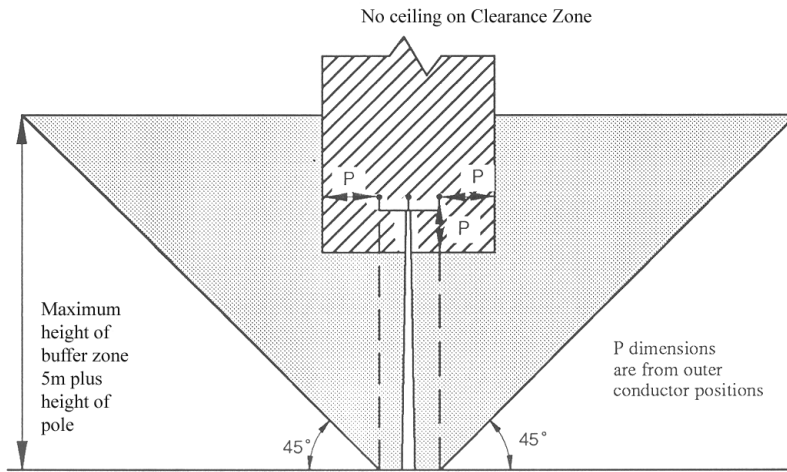

D.2—bushfire risk area—not insulated 33kV to 66kV—mid span (as shown in diagrams D.3 and D.4)

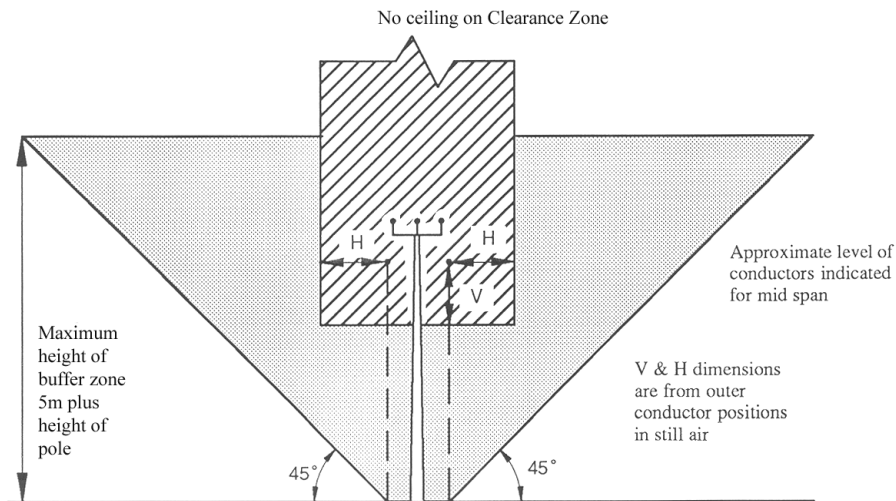

D.3—bushfire risk area—not insulated 33kV to 66kV—view of clearance zone from above

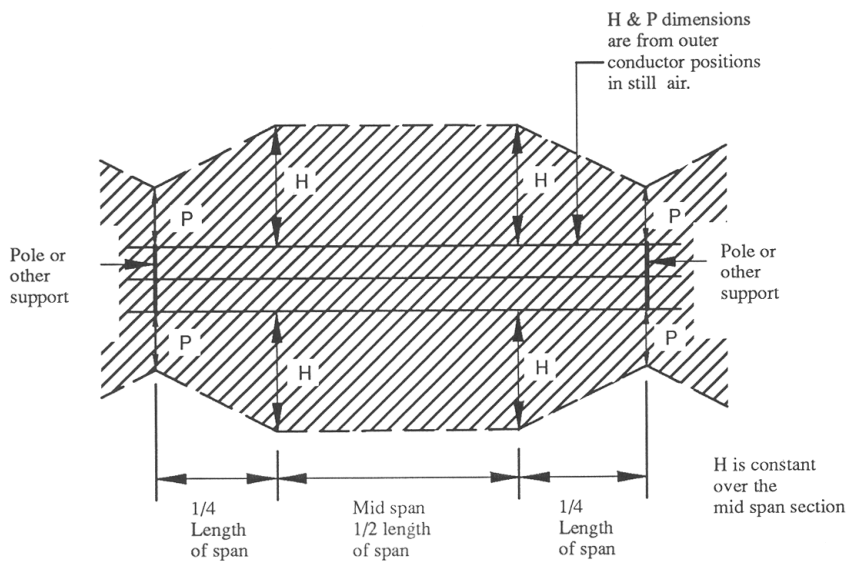

D.4—bushfire risk area—not insulated 33kV to 66kV—view of clearance zone from side

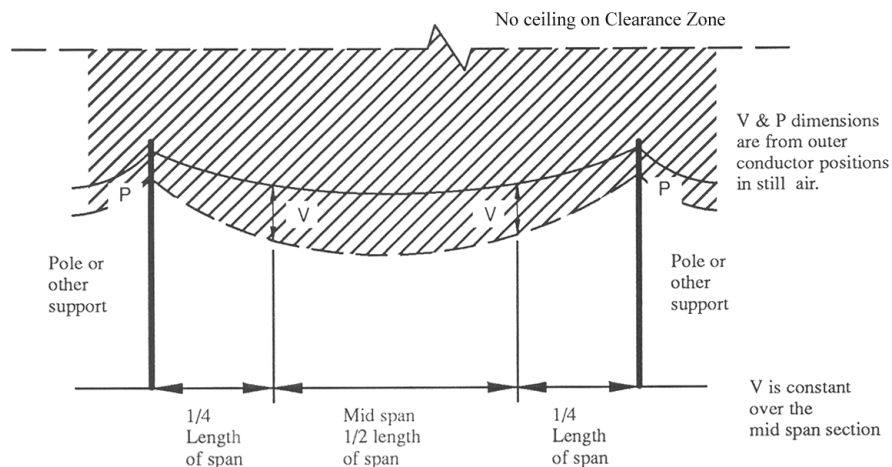

(5) **Diagram E—bushfire risk area—not insulated 132kV to 275kV**

These diagrams apply to a powerline, the conductors of which are not insulated, constructed to operate at a voltage from 132kV to 275kV inclusive.

Diagram E.1 shows the zones at the pole or other support at the end of each span of the powerline.

Diagram E.2 shows the zones at mid span (as shown in diagrams E.3 and E.4) for each span of the powerline.

Diagrams E.3 and E.4 show the manner in which the clearance zone extends along the length of each span of the powerline.

Although not shown in diagrams E.3 and E.4, the buffer zone as shown in diagrams E.1 and E.2 extends along the length of each span of the powerline.

The values of V, H, S, B and P are set out in Table 4 in clause 5.

The 45° component of the clearance zone is determined as being 3 m inside the buffer zone.

E.1—bushfire risk area—not insulated 132kV to 275kV—at each end of a span

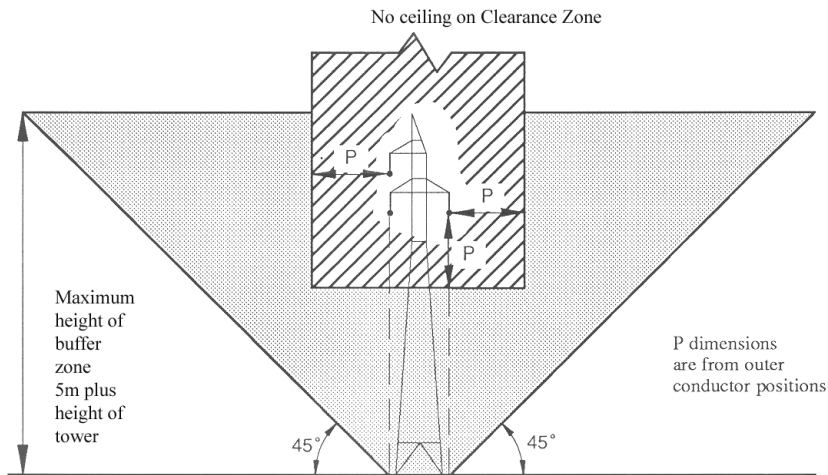

E.2—bushfire risk area—not insulated 132kV to 275kV—mid span (as shown in diagrams E.3 and E.4)

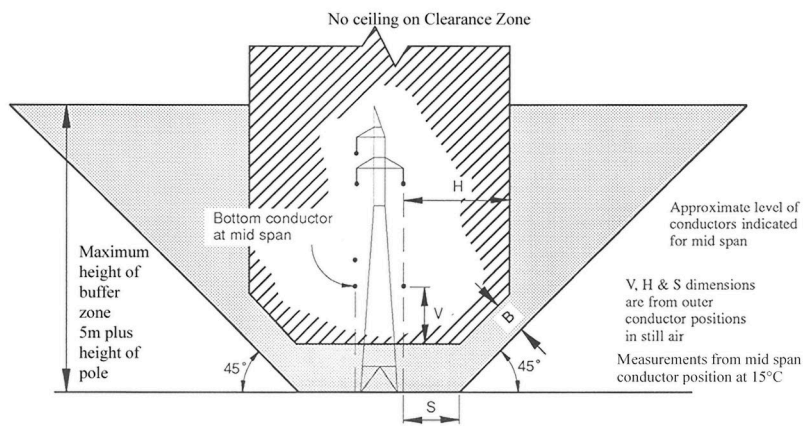

E.3—bushfire risk area—not insulated 132kV to 275kV—view of clearance zone from above

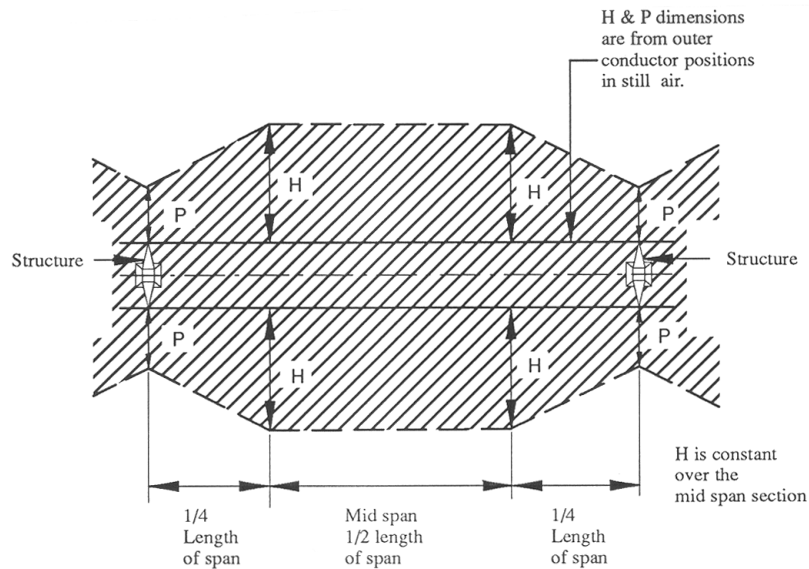

E.4—bushfire risk area—not insulated 132kV to 275kV—view of clearance zone from side

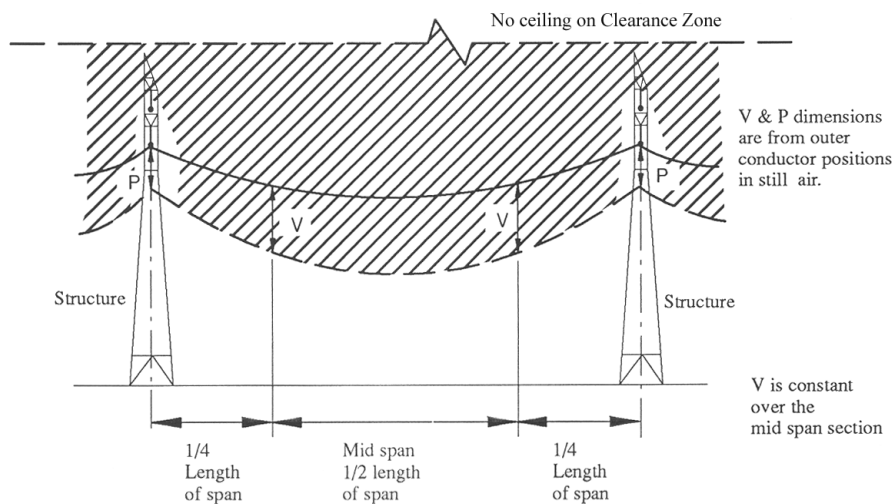

5—Tables for determination of value of V, H, B, S and P

- (1) The values of V, H, B, S and P are determined by the voltage at which the powerline is constructed to operate and the length of the span concerned.
- (2) For 132kV and 275kV lines, a "stepout" S is required for the buffer zone.
- (3) For the purposes of compliance with the requirements of these regulations as to clearance of vegetation from around powerlines, as an alternative, the value of S may be taken to be that fixed for S* in Table 4 provided that the clearance zone will still extend at least—
 - (a) in the case of a 132kV line—1.5 m; or
 - (b) in the case of a 275kV line—2.5 m,

beyond any point to which the line may swing or sag at a wind pressure of 400Pa (taking into account the length of the span concerned and the characteristics of the line).

- (4) The values given are in metres.
- (5) The clearance to uninsulated LV conductors in non-bushfire risk areas is 0.1 m for the length of the line and beyond termination poles or structures, as is also the case for fully insulated conductors in any part of the State.
- (6) The value of P determines the clearances required beyond a pole where a line terminates, in addition to clearances at poles or other supports along the length of the powerline.
- (7) A buffer zone of 1 m and no clearance zone applies where a neutral conductor (CMEN) is not within the clearance zone or buffer zone of an adjoining conductor.
- (8) The clearance to Insulated Unscreened Conductor ("IUC" or "CCT") is 0.5 m for the length of the line and beyond termination poles or structures, in any part of the State.

Table 1—Bare or covered conductor at operating voltages of 240V to 11kV

Voltage	All spans	Span (in metres)									
		0–50		Over 50–100		Over 100–150		Over 150–200		Over 200	
	P	V	H	V	H	V	H	V	H	V	H
Voltage not exceeding 480V in the bushfire risk area only	0.5	1.0	1.0	1.5	2.5	1.5	3.5	—	—	—	—
7.6kV and 11kV in bushfire and non-bushfire risk areas	0.5	1.5	1.5	2.0	2.5	2.5	3.5	2.5	4.5	2.5	6.0

Table 2—Bare or covered conductor at an operating voltage of 19kV

Voltage	All spans	Span (in metres)									
		0–100		Over 100–200		Over 200–300		Over 300–400		Over 400	
	P	V	H	V	H	V	H	V	H	V	H
19kV single wire earth return (SWER)	0.5	1.0	1.0	1.0	2.5	1.5	5.0	2.0	7.0	2.0	9.0

Table 3—Bare or covered conductor at operating voltages of 33kV and 66kV

Voltage	Span (in metres)												
	All spans			0–100	Over 100–200	Over 200–300	Over 300–400	Over 400–500	Over 500–600	Over 600–700	Over 700–800	Over 800–900	Over 900
	V	P	B	H	H	H	H	H	H	H	H	H	H
33kV	2.5	0.5	2.0	2.5	4.5	6.5	9.5	14.0	19.0	25.0	32.0	39.5	48.0
66kV	3.0	1.0	2.0	2.5	4.5	6.5	9.5	14.0	19.0	25.0	32.0	39.5	48.0

Table 4—All conductors operating at voltages of 132kV to 275kV—V, H and S

Voltage	All spans			Span (in metres)															
	P	B		0–100	Over 100-150	Over 150-200	Over 200-250	Over 250-300	Over 300-350	Over 350-400	Over 400-450	Over 450-500	Over 500-550	Over 550-600	Over 600-650	Over 650-700	Over 700-750	Over 750-800	Over 800
132kV	2.5	3.0	V	3.0	3.0	4.0	5.0	5.0	5.0	6.0	6.0	6.0	6.0	6.0	6.0	6.0	6.0	6.0	6.0
			H	3.0	4.0	6.0	8.0	10.0	11.0	14.0	17.0	20.0	23.0	28.0	32.0	37.0	41.0	47.0	58.0
			S	0	2.0	2.0	4.0	5.0	6.0	8.0	10.0	12.0	14.0	16.0	19.0	22.0	25.0	29.0	36.0
			S*	0	1.0	1.0	3.0	3.0	5.0	5.0	8.0	8.0	13.0	13.0	19.0	19.0	26.0	26.0	32.0
275kV	4.5	3.0	V	4.5	4.5	5.0	6.0	7.0	7.0	7.0	8.0	8.0	8.0	8.0	8.0	8.0	8.0	8.0	8.0
			H	4.5	5.0	6.0	7.0	9.0	10.0	11.0	13.0	15.0	17.0	19.0	22.0	24.0	27.0	30.0	37.0
			S	1.0	2.0	2.0	3.0	4.0	5.0	6.0	7.0	8.0	10.0	11.0	13.0	15.0	17.0	19.0	24.0
			S*	1.0	2.0	2.0	3.0	3.0	4.0	4.0	6.0	6.0	9.0	9.0	12.0	12.0	16.0	16.0	21.0

3.5m rule

Where the application of the value set out in Table 4 would result in the bottom edge of the clearance zone having a vertical distance from ground level of less than 3.5 m, the bottom edge of the clearance zone shall have a vertical distance from ground level of 3.5 m irrespective of the vertical distance it would otherwise have had from ground level by virtue of the value of V.

6—Technical Regulator may determine values for clearance zone around particular powerline in certain circumstances

- (1) The Technical Regulator may, on application by an electricity entity with a duty under section 55 of the Act in relation to an overhead powerline, determine that for the purposes of that duty in relation to a specified portion of the powerline—
 - (a) the value of V, H, B or S is to be a specified number of metres instead of the value given in clause 5; or
 - (b) a particular method may be used to calculate the value of V, H, B or S instead of V, H, B or S having the value given in clause 5.
- (2) The Technical Regulator must not make a determination under subclause (1) unless satisfied by the electricity entity that the clearance zone will still extend at least—
 - (a) in the case of a 240V to 11kV, 19kV or 33kV line—0.5 m; or
 - (b) in the case of a 66kV line—1.0 m; or
 - (c) in the case of a 132kV line—1.5 m; or
 - (d) in the case of a 275kV line—2.5 m,beyond any point to which the line may swing or sag at a wind pressure of 400Pa (taking into account the length of the span concerned and the characteristics of the line).
- (3) An application under this clause must—
 - (a) be made in a form approved by the Technical Regulator; and
 - (b) contain the information specified in the form; and
 - (c) be accompanied by an application fee fixed by the Minister.
- (4) A determination under this clause must be in writing.
- (5) The Technical Regulator may, by notice in writing to an electricity entity with a duty under section 55 of the Act in relation to a powerline to which a determination under this clause relates, vary or revoke the determination.

Schedule 2—Planting or nurturing vegetation near public powerlines

1—Interpretation

In this Schedule—

approved vegetation means species in the list of vegetation with an expected mature height of 3 m or less published on a website determined by the Technical Regulator;

exempt vegetation means—

- (a) vegetation (such as small plants that produce flowers or vegetables, ground covers, cereal crops or small bushes or shrubs) with an expected mature height of less than 2 m; or
- (b) vegetation in relation to which an exemption is in force under these regulations;

permitted vegetation means species in the list of vegetation with an expected mature height of more than 3 m but not more than 6 m published on a website determined by the Technical Regulator;

prescribed distance means—

- (a) in the case of a powerline constructed to operate at a voltage listed below—the distance set out below in relation to that voltage:

Voltage	Distance (in metres)
500kV	19.0
275kV	12.5
132kV, other than a single pole	15.0
132kV, single pole	10.0
66kV	6.5

- (b) in any other case—6 m.

2—General rules

- (1) Subject to clause 3, only vegetation of a kind set out in the third column of Table 1 may be planted within the distance set out in the second column from a powerline of a kind set out in the first column.
- (2) Subject to clause 3, only vegetation of a kind set out in the third or fourth column of Table 1 may be nurtured if it is growing within the distance set out in the second column from a powerline of a kind set out in the first column.

3—Exemption

Vegetation may be planted in proximity to a public powerline in a non-bushfire risk area and any such vegetation may be nurtured, if—

- (a) the vegetation is planted in replacement of vegetation in a stand or avenue of vegetation situated along a road; and
- (b) the vegetation is of the same species as that being replaced.

4—Table

Table 1—General rules

Powerline	Distance within which planting or nurturing is controlled	Vegetation which may be planted or nurtured	Additional vegetation which may be nurtured
Overhead public powerline, the conductors of which are not insulated, in the bushfire risk area.	Prescribed distance from centreline.	Approved vegetation. Exempt vegetation.	Any vegetation planted or self-sown before 1 November 1988.

Electricity (Principles of Vegetation Clearance) Regulations 2021—12.8.2021 to 31.8.2021—uncommenced

Schedule 2—Planting or nurturing vegetation near public powerlines

Powerline	Distance within which planting or nurturing is controlled	Vegetation which may be planted or nurtured	Additional vegetation which may be nurtured
	More than the prescribed distance but less than twice the prescribed distance from centreline.	Approved vegetation or permitted vegetation. Exempt vegetation.	Any vegetation planted or self-sown before 1 November 1988.
Any other overhead public powerline.	Prescribed distance from centreline.	Approved vegetation or permitted vegetation. Exempt vegetation.	Any vegetation planted or self-sown before 1 November 1988.
Underground public powerline constructed to operate at a voltage of 66kv or more.	3 m from centreline.	Approved vegetation. Exempt vegetation.	Any vegetation planted or self-sown before 1 November 1988.
Any other underground public powerline.	No control.		

Schedule 3—Revocation of *Electricity (Principles of Vegetation Clearance) Regulations 2010*

The *Electricity (Principles of Vegetation Clearance) Regulations 2010* are revoked.

Legislative history

Notes

- For further information relating to the Act and subordinate legislation made under the Act see the Index of South Australian Statutes or www.legislation.sa.gov.au.

Principal regulations

Year	No	Reference	Commencement
2021	114	<i>Gazette 12.8.2021 p3018</i>	1.9.2021; r 2